



TuffCore™ Installation Guide

Job Site/Home Owner and Installer's Responsibility

Note: The suggestions in this booklet are only a guide until you receive the actual boxes of flooring. It is highly recommended that the job site/home owner consult a professional for any questions regarding proper installation. This guide is not a substitute for the official installation instructions included in every box of TuffCore flooring and is subject to change without notice. For the most up to date installation and maintenance requirements please visit www.NationalFlooringProducts.com.

***** Only install flooring in rooms under adequate lighting conditions. Taking this important step will allow you greater visibility and help you avoid costly installation mistakes. *****

- It is the job site/home owner and installer's responsibility to inspect ALL TuffCore flooring prior to installation. Inspect every plank for inconsistency with the finish, texture, milling, color, graining, locking system integrity, dimensions, and the suitability of the TuffCore flooring product to its environment. TuffCore flooring products installed with pre-existing defects or incorrectly acclimated **CANNOT** be claimed after installation.
- Verify there are enough materials to complete the job with a minimum of 2% extra for future plank replacements. The manufacturer is not responsible for supplying materials for plank replacements unless the defective boards exceed 5% of the total floor installed.

General Job Site/Home Condition

Important: The requirements listed below are considered standard practices for the flooring industry and are required by most building codes. Following these simple guidelines will greatly extend the life of any fixture in the job site/home. Local building codes may vary and will prevail.

- Make sure the crawl space has at least 18" clearance and is covered with a minimum of 6 MIL plastic with all seams overlapped 18" and fully sealed with a moisture proof tape. It is recommended to use an approved moisture retarder between the wood sub-floor and TuffCore flooring (see approved moisture retarders below for details).
- To prevent excessive moisture build up all crawl spaces must have at least 1.5% cross ventilation on the exterior of the home for every 100ft² of the crawl space or an air exchanger will be needed.
- Drainage from roofs, rain gutters, and other sources of moisture around the job site/home must be directed away from the site. Excessive moisture coming from these sources can severely damage any flooring product.
- All exterior doors, windows, drywall, painting, venting, heating, and cooling systems must be properly installed prior to the delivery of the TuffCore flooring to the job site/home. Do not store TuffCore in exterior sheds or garages that are not temperature controlled.
- All heating and cooling systems are required to be installed and functioning for at least 7 days before the installation of the TuffCore flooring begins.
- The job site/home heating and cooling systems must be able to maintain a minimum of 62 degrees Fahrenheit in winter and 75 degrees Fahrenheit in summer before, during, and after the TuffCore flooring is installed, even when the job site/home is not occupied.
- The job site/home must be able to maintain a 30% - 50% relative humidity before, during, and after the installation, even when the job site/home is not occupied.
- Small humidifiers may not be capable of properly maintaining the humidity levels in large job sites/homes. Your local heating and cooling air service contractors can provide information for automatic humidifiers/dehumidifiers that work with your heating and cooling systems.
- Prior to the installation the TuffCore flooring must be acclimated for a minimum of 24 hours in the temperature-controlled room it is being installed in.
- TuffCore flooring is not recommended, nor will it carry a manufacturer warranty, if installed in any area of the job site/home that has extreme temperature and moisture fluctuations. For example: saunas, hot tub/pool rooms, green houses, exterior porches, or garages.

Radiant Heat Requirements for TuffCore

- TuffCore flooring can be installed over in-floor radiant heat.
- There are unique installation requirements for TuffCore flooring. It is the responsibility of the job site/home owner and installer, prior to installation, to check with the manufacturer for a current list of approved installation methods and underlayment requirements.
- Operate the in-floor radiant heat systems for at least 14 days prior to the TuffCore flooring being installed. All moisture in the substrate must be evaporated off. This will also ensure all systems are in good running condition.
- **In-Floor Radiant Heat Systems: At no time during the life of the floor should the boiler exceed 110 degrees on Fahrenheit setting, or the substrate surface temperatures ever exceed 85 degrees Fahrenheit.**
- A humidity control system (humidifier) must be installed and properly functioning one week before, during, and after the installation for the life of the floor. This helps prevent shrinkage caused by moisture/temperature changes from the in-floor radiant heat system.
- The in-floor radiant heat systems **CANNOT** be installed directly below the TuffCore flooring. It must be embedded in the concrete, gypcrete, or installed under the wood sub-floor. This will ensure the radiant heat is evenly distributed across the substrate before the heat comes into contact with the TuffCore flooring (see illustration below).

In-Floor Radiant Heat Moisture Retarder Requirements

Note: Although moisture will not affect the TuffCore integrity, excessive accumulation of moisture can contribute to mold growth. If the concrete slab moisture is a concern (above 5LBS/24HR), it is recommended to use a vapor barrier.

Be sure to only use moisture retarders that are approved for in-floor radiant heat systems. Check with local building codes and the manufacturer of the radiant heat systems for recommendations. **Note: Do not use any moisture retarder that is primarily oil or tar based over any type of in-floor radiant heat substrate, unless it is clearly marked suitable for radiant heat. It may give off toxic fumes.**

- **Floated Click-Lock TuffCore With Pad Attached:** It is recommended to use Aqua Bar (B) underlayment paper as a vapor retarder. It will act as a slip sheet and will prevent dirt and dust from working up through the joints.
- **Floated Click-Lock TuffCore (Without Attached Pad):** If an underlayment/pad is desired, National Flooring Products recommends our 60PVC1510 PVC 1.5mm underlayment/pad with a built-in 6 MIL vapor barrier. Follow the underlayment manufacturer guidelines for in-floor radiant heat installations.
- **Glue-down TuffCore With/Without Attached Pad:** Use an approved, troweled-on sealant or two-part epoxy coating that is compatible with the adhesive. Some brands of adhesive simplify this by having a moisture retarder built in. For example: Taylor MS-Plus Resilient adhesive has moisture blocker properties when installed correctly and will easily do the job. Be sure to closely follow the sealant and adhesive manufacturer's application procedures. All moisture protection and bond warranties come solely from the adhesive and sealant manufacturers.

Turn In-Floor Radiant Heat On or Off During Installations

- For TuffCore floors, it is required to turn off the in-floor radiant heat system a minimum of 12 hours before and during the installation. (For glued down applications follow adhesive manufacturer's application procedures after install) Raise the temperature slowly to liveable conditions. Never raise the temperature up or down more than 5 degrees in a 24 hour period.

Important: One of the leading causes of TuffCore flooring failures is extreme moisture level inconsistencies and/or rapid swings in temperatures on the job site/home. TuffCore flooring performs best when the room it is installed in has moisture levels in the air between 30% - 50% relative humidity with air temperatures ranging between 65-75 degrees Fahrenheit. The humidity level and temperature of the air will also greatly impact the performance life of your furniture, cabinets, doors, and trim work.

Acclimation Tips for TuffCore

Important: TuffCore boxes can be packaged and manufactured differently. Be sure to read the manufacturer's installation guides inside each box for its particular requirements on acclimation. The information below is only a general guide until you receive the actual boxes of TuffCore.

- Installing TuffCore flooring before it has properly acclimated will greatly increase the chances of expansion and contraction issues and may make it more difficult to install.
- Depending on the environment, TuffCore floors will usually acclimate within 24 hours.

- Always acclimate the TuffCore flooring in the temperature controlled room it will be installed in.
- During acclimation, stack the boxes squarely on top of each other to prevent plank warping. Do not stack boxes higher than 5 ft. Do not lean boxes against walls or other objects as this will warp the flooring and the manufacturer's warranty will be void.
- Keep the stacked boxes of TuffCore flooring 3" apart to allow air circulation around the boxes.
- Never cover TuffCore flooring before, during, or after installation with any type of plastic or tar paper. It must be allowed to breathe. Use only breathable materials like construction paper (FortiBoard) to protect a TuffCore floor.
- Propane heaters are not an approved source of heat and can give off extreme amounts of moisture. The manufacturer warranty will be void if the job site/home heating and cooling system were not fully operational at the time of installation.

Approved Substrates for TuffCore Floors:

Plywood/OSB:

- Acceptable minimum wood sub-floor thickness is determined by the distance between the joists/trusses. Vertical deflection must be under a 1/4" over a 6' span when walked across.
 - ◊ When joists are 16" o/c or less; minimum acceptable thickness is 5/8" CDX plywood or nominal 3/4", OSB 40LB Minimum density, T&G, with a TECO or APA certification stamp.
 - ◊ When joists are 16" o/c up to 19.2" o/c; minimum acceptable thickness is 3/4" plywood or nominal 3/4", OSB 40LB Minimum density, T&G, with a TECO or APA certification stamp.
 - ◊ When joists are 19.2" o/c up to 24" o/c; minimum acceptable thickness is 7/8" plywood or nominal 1", OSB 40LB Minimum density, T&G, with a TECO or APA certification stamp.

Cured concrete/Gypcrete:

- Cured concrete must be over 3000 PSI. Cured gypcrete must be over 2500 PSI. Both of these substrates must be free of any type of top coating, plaster, paints, or curing compounds.
- All concrete or gypcrete substrates must be cured for a minimum of 60 days before TuffCore is ever installed.
- Concrete or gypcrete substrates must be tested for moisture content when using the glue down installation method.
- Concrete moisture testing should be performed by ASTM F1869 Calcium Chloride Tests with levels not exceeding 5LBS per 1000 ft² for a 24 hour period or the ASTM F2170 In-Situ Relative Humidity Test with readings exceeding 80%.
- Gypcrete moisture testing should be performed using the ASTM F2170-11 In-Situ Relative Humidity Test Standard. For more information visit RHSPEC.com

Particle Board (Underlayment-grade):

- The only install method that can be used directly over underlayment-grade particle board is the floating method, as long as there are no current or future moisture concerns from below or above. If moisture comes in contact with the particle board it will swell and void the manufacturer's warranty.

General Substrate Conditions for TuffCore

- TuffCore flooring can be installed over wood sub-floors that are ON or ABOVE GRADE and over concrete or gypcrete substrates that are BELOW, ON, or ABOVE GRADE.
- Wood sub-floors when walked on must not exceed 1/4" deflection over a 6' span. If it does, this condition must be corrected before the TuffCore installation begins. The floor will not stiffen up after the TuffCore flooring is installed.
- Fix all squeaks coming from the wood sub-floor prior to installation. Use wood screws, minimum of 2-1/2" lengths, fastened every 6" through the wood sub-floor into the joist. Squeaks in the sub-floor will not go away after the TuffCore floor has been installed.
- All substrates must be flat and free of dust, loose particles, paint, drywall compound, and structurally sound.
- If leveling of the substrate is required use only cement-based leveling compounds. Be sure to follow the leveling compounds manufacturer installation guidelines. Sand and/or flatten the substrate to within 1/4" dip or rise over 10' or 3/16" dip or rise over 6' for all floated installations.

Important: Hand held angle grinders with special cupped diamond grinding wheels and vacuum attachments can be rented or purchased from your local rental or home building center. This system works well with any type of substrate. Use precautions when sanding any surface. Check the substrate out for any health hazards.

General Installation Specs

- Avoid installing TuffCore plank pieces less than 8" in total length against walls or on ends.
- Room humidity and temperature can vary according to the season, so it is vital that the floor is able to expand and contract. Therefore, make sure you leave minimum expansion gaps of 1/4" on all sides of the floor, around pipes, thresholds, under doors, and around any fixed/stationary objects.
- It will generally be necessary to saw some flooring panels during installation. To obtain a clean cut, the pattern side should face down if using a jigsaw, saber saw or circular handsaw and up when you use a handsaw, table saw or a crosscut saw.
- Before installation begins, use a jamb saw to undercut all door casings and vertical objects coming off the floor. To achieve the correct height, combine a piece of the underlayment/padding and TuffCore flooring together to use as a guide for the saw. Be sure to clean out all debris from under the jambs. This will allow the flooring to slide underneath the object for a clean professional look.
- Install the molding over the plastic membrane that runs up the wall from under the floor. Never attach the molding to the floor. This allows the floor to expand and contract under the molding. For a perfect finish around pipes, use rosettes or caulking in places where profiles or skirting cannot be placed, fill expansion gaps with matching caulking.

Approved High-Density Underlayment Padding For TuffCore Click-Lock 5.5mm – 8.5mm

- Clicked together TuffCore does not have to be installed over any type of underlayment pad. If the end user would like additional comfort and improve sound absorption, using National Flooring Products 60PVC1510 high-density 1.5mm thick underlayment is approved.
- If an underlayment is not desired or is already attached then it is recommended to install a layer of Aqua Bar (B) underlayment paper. It will act as a slip sheet and will help prevent dirt and dust from working up through the joints.
- Do not use underlayment/pad that are not approved for TuffCore. If the underlayment/pad does not meet the minimum standards and does not support the flooring when walked on, the floor will come apart. The flooring **WILL NOT BE COVERED** under the manufacturer warranty.
- Never install an additional underlayment/pad beneath TuffCore that already has a pad attached to the planks.

Approved Floating Method (TuffCore 5.5mm-8.5mm Valinge 2G system)

Never install cabinetry, islands, or other permanent fixtures on top of a floated floor. Never use nails to secure anything to the floor. The floor must be allowed to float. As you install the click flooring, ensure all seams are fully engaged before moving on to the next row. This may require additional measures (Tapping Block) beyond the initial click of the locking system.

For TuffCore Click-Lock 5.5mm to 8.5mm flooring, transition strips/breaks are recommended every 40 feet (lengthwise), every 40 feet (widthwise). It is recommended to glue the floor down for floors larger areas exceeding 40' either directions or job sites with heavy rolling equipment, wheel chairs, or high traffic.

NOTE: The Valinge 2G system is only used for TuffCore between 5.5mm-8.5mm thick. You **must** verify which locking system your flooring has before beginning any installation.

The Valinge 2G system is a patented locking profile for installing thicker TuffCore planks without using glue. The panels are clicked together simply and easily thanks to the ingenious shape of the 2G locking profile.

Angle-Tap Installation method: Position the panel to be installed at an angle of 20 to 30° to the panel already installed. Move the panel gently up and down while exerting forward pressure. The panels will automatically click into place. Tongue-to-groove is the recommended direction for installation.

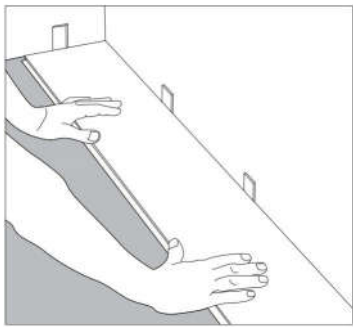

1. Leave at least 1/4" expansion gap around all perimeters and vertical objects coming off the floor.
2. Insert spacers at ends and edges where the planks will meet the walls and vertical objects.

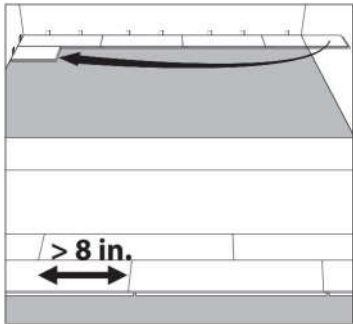

4. Use a cut piece to start the second row. **NOTE: End joint spacing must be at least 8" for all adjacent rows. If any piece is less than 8" in total length, discard it and do not use it.**

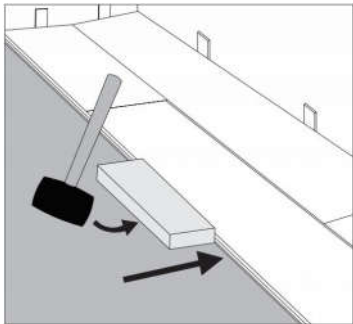

6. Use a scrap piece of flooring as a tapping block and tap on the long edge of the plank to ensure that the locking system fully engages. **NOTE: Any gapping may disrupt the locking system and prevent the floor from performing well.**

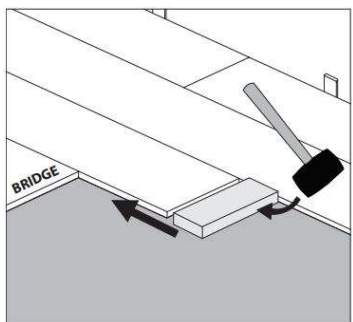

8. Using a scrap piece (with a factory end joint) as a tapping block, tap the end of the plank to engage the locking system covered by the bridge. **Be cautious to not damage the locking profile when tapping.** Continue installing until you reach the end of the row.

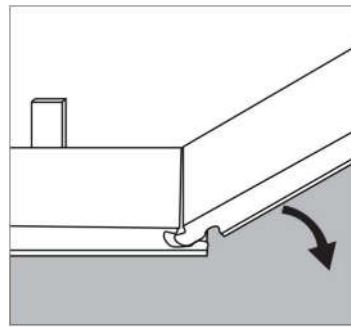

3. Start the first row by inserting the short end of the plank (tongue first) into the groove at an angle, then rotating downward to lock it in place. Continue laying planks to establish the first row.

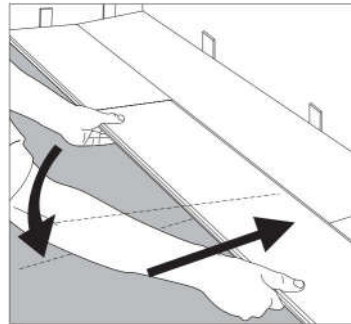

5. Engage the locking system on the long side of the next planks by inserting the tongue at an angle, then rotating downward. Slide this plank toward the end of the previously installed plank until the tongue just touches the groove.

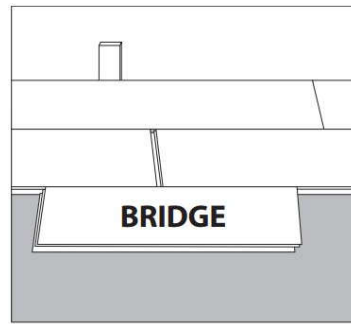

7. Attach a scrap piece of flooring (with an intact factory end joint) to cover the gap where the tongue is touching the groove on the planks installed in **Step 5**. This piece is called a "bridge".

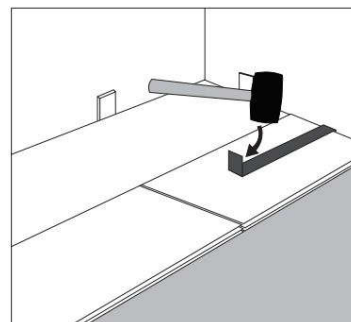

9. At the end of the row, use a hammer and pull bar to engage the locking system of the final piece in the row. Install a 1/4" spacer at the row end. Repeat this process until the final row of flooring.
10. At the final row, use the hammer and pull bar to lock the long edges of the planks as well as the row ends.

Approved Tuffcore Glue-Down Method (Only for Approved 5.5mm-8.5mm TUFFCORE)

Important: It is not recommended to glue TuffCore flooring down over particle board sub-floors. Either remove the particle board or install new 1/4" thick plywood over the particle board, then install the new TUFFCORE floor over the plywood. Since the warranty is provided solely by the adhesive manufacturer, be sure to use their recommended trowels, and instructions. Coverage of 98% is required. Periodically check to make sure the trowel notches are not worn out.

Glue down procedure

Use only adhesives specifically approved for TuffCore flooring. Never use any non-approved adhesives. (Approved adhesives are: polymer-based and acrylic emulsion adhesives like Taylor MS Plus Resilient and Parabond 5080 Pressure Sensitive Adhesive) All adhesive and bond warranties come solely from the adhesive manufacturer. Follow all adhesive manufacturer guidelines, trowel sizes, and suggestions. Most flooring manufacturers require that the adhesive is adhered to a minimum of 98% of the bottom of the TuffCore flooring. Periodically check to make sure the trowel notches are clean and not worn out.

- Leave at least 1/4" expansion gap around every row end and 1/4" expansion gap around the row widths.
- Most adhesives can be cleaned off of the TuffCore floor surface with light mineral spirits on a terry cloth rag, followed by a rinse with clean water on a rag. Do not pour cleaning products or adhesive removers directly onto the floor.
- Use only green/blue 3M/Scotch Tape model #2080 to hold the TUFFCORE together while the adhesive is drying (minimum of one hour). Remove the tape within 24 hours to avoid damage to the finish. Allow the glue to dry 24 hours before heavy traffic begins. Do not use duct tape or packing tape as they will damage the TUFFCORE 's finish.
- During the installation, carefully roll the top of the TUFFCORE floor with a soft 100lb. 3-section roller while the adhesive is still active, and again usually within 45-60 minutes. Be sure to always follow the adhesive manufacturer guidelines and installation procedures.
- Allow the first rows to dry for a minimum of one hour before installing additional rows. This will ensure a solid and straight platform to install the next rows against.
- Working off the longest straight wall, snap a chalk line parallel with the wall that is equal to the width of the TUFFCORE flooring plus enough room for the expansion gap (1/4"). Use spacers to maintain the proper expansion gap around all walls and vertical objects coming off the floor.
- Keeping the tongue facing out, glue 3-5 rows down while using the snapped line as a guide.
- It is recommended to not walk on the floor for a minimum of 24 hours to allow the glue to set properly.
- Once the TUFFCORE floor installation is complete, remove all spacers that were used to maintain the expansion gap.

DO NOT WET-CLEAN FLOOR FOR A MINIMUM OF 72 hours. THIS WILL ALLOW THE ADHESIVE TO CURE PROPERLY.

Installation Tips For How to Improve the Look of Your TuffCore Floor

Important: Install your TuffCore floor under good lighting conditions. Examine each plank carefully. Contact the dealer immediately if the material is not acceptable. Materials installed with visible defects are not covered under warranty. The manufacturer will not assume any responsibility for installed materials.

- When ready to install, open up and work with at least five boxes at a time. Check for any defects and thoroughly mix the planks to avoid groupings of similar colors, sizes, and graining. Be sure to stack the planks on a flat surface to reduce plank warping.
- Plank flooring generally shows fewer seams and imperfections if it is installed lengthwise into the light.
- Avoid "H-Seams" in the TuffCore flooring for cosmetic and structural reasons. "H-Seams" are when two flooring end joints are laid parallel to each other within three rows.
- For both cosmetic and structural reasons stagger end joints more than 6" (and sometimes, more than 8") from each other.
- The room will seem longer whichever direction the TuffCore flooring is laid lengthwise.

How to Protect TuffCore Floors During and After Installation

- After each section of TuffCore flooring has been installed and thoroughly cleaned, cover your floor with a breathable construction paper (FortiBoard).
- During construction, vacuum the floor as often as it takes to keep the floor free of dirt and construction debris. (**Never** use a beater brush)
- If drywall repairs or any type of sanding is needed, thoroughly cover the floor. Dust and grit will damage the TuffCore's finish and is very difficult to remove if it gets into the pores. Do not wet mop these types of dust. Always use a vacuum (without a beater brush) to remove any construction dust if needed.
- Before furniture goes onto the TuffCore floor, apply approved 3/16" thick heavy duty pads under all furniture feet. (Furniture with rollers or casters are **not approved** for use on TuffCore flooring)
- Never roll or drag anything heavy over TuffCore floors. It will make indentations or scratches in the surface. Always use a soft-tire dolly when moving objects.

END