

Assembly Instructions

Jr. Bar Pro



Thank you for purchasing the Jr. Bar Pro. We hope you will enjoy years of use of this product.

After opening the boxes, please check the parts list to make sure all pieces have arrived in good condition. If you have any questions during this assembly process, please call customer service at 1-800-331-4362.



WARNING

- Serious injury (including permanent paralysis or death) could result from any activity involving motion, rotation or height.
- All users of this equipment assume this risk of serious injury.
- Mats and pits cannot and do not eliminate hazards.

Safety Instructions

ALWAYS:

1. Consult an instructor prior to use.
2. Use equipment **ONLY** under the supervision of trained and qualified instructors.
3. Use equipment with trained spotters and the proper spotting equipment.
4. Check equipment before use for proper positioning; equipment can move during use.
5. Follow a progressive learning pattern. Assure basic skills are achieved before attempting more advanced skills.
6. Use equipment **ONLY** when all hard exposed surfaces are protected with proper mats.
7. Assure that all inflatable equipment has sufficient air pressure to avoid injury.

DO NOT use the apparatus with damaged, worn or missing parts.

DO NOT allow more than one person at a time to use the equipment.

Parts List

Parts List:

- (1) kip bar subassembly
- (2) vertical supports
- (1) center-beam
- (2) side legs
- (2) spring-detent knobs (D-2)
- (4) hand-knobs (D-1)
- (1) 6mm allen wrench
- (4) button-head cap screws
- (4) lock washers
- (4) flat washers

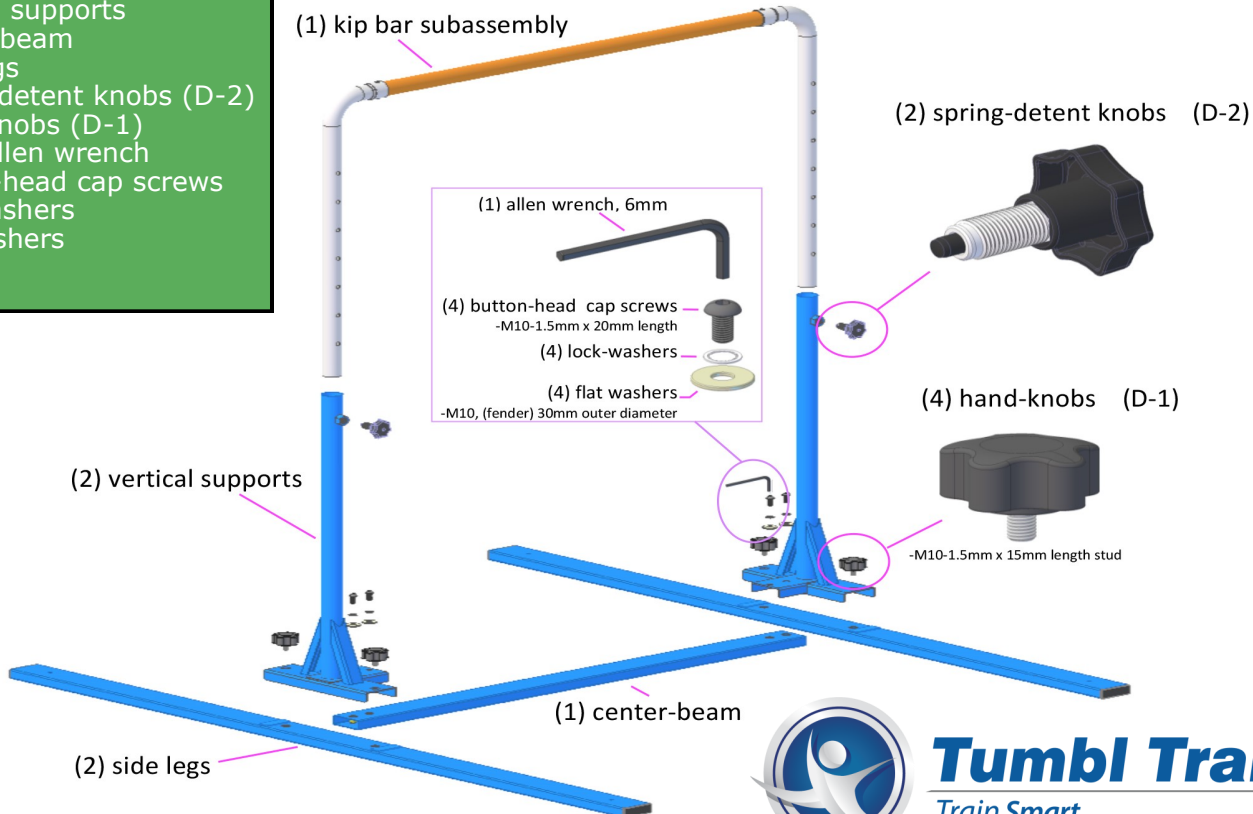

① Attach vertical supports to center-beam

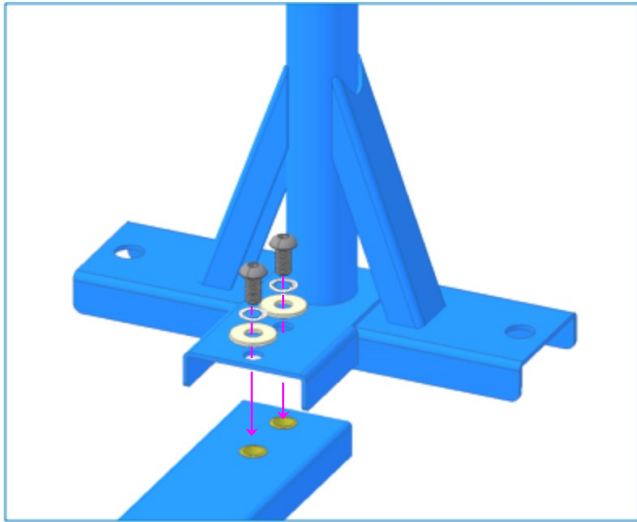

② Attach side-legs to vertical supports

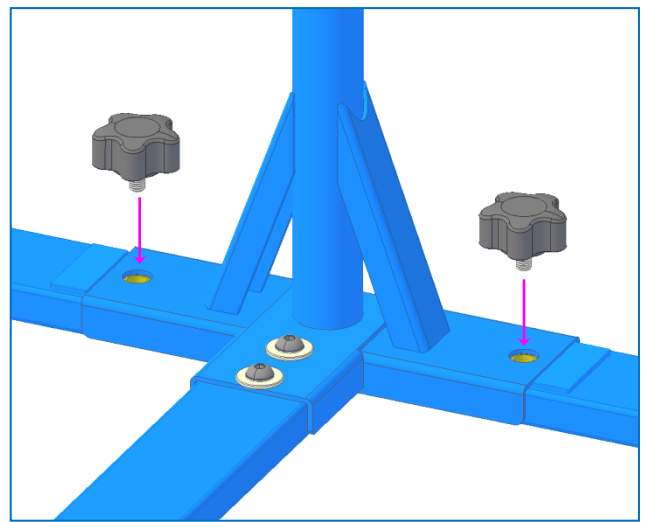

③ Insert kip-bar into vertical supports

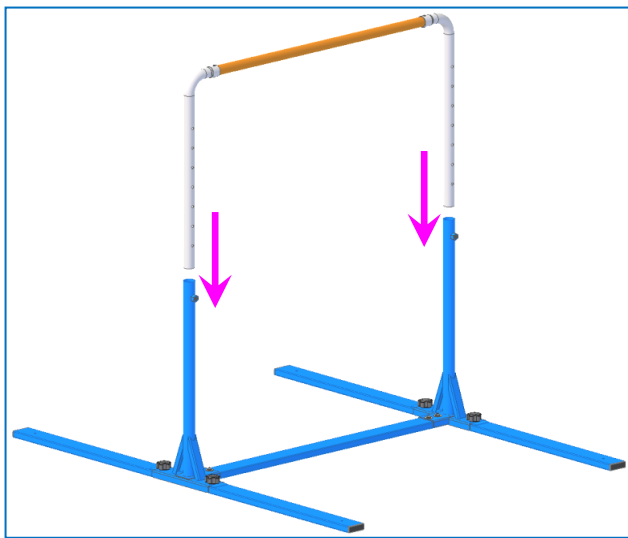

④ Align tube holes and insert spring-knobs

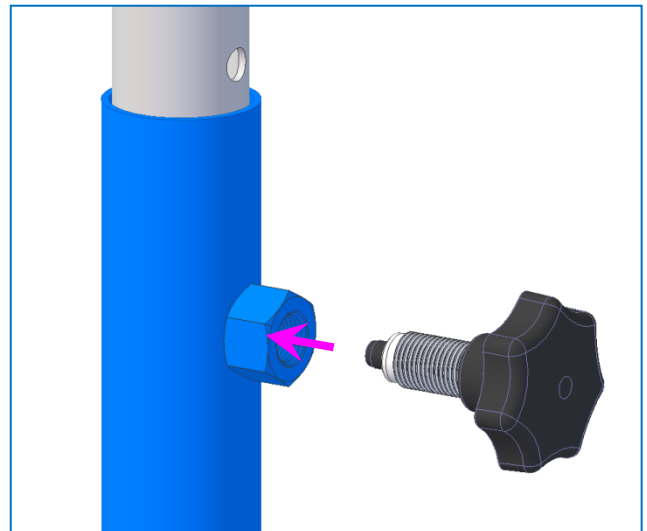

- Assure that detent-pin is in desired kip-bar tube hole, then fully tighten knob to secure fit.

To adjust kip bar height:

- loosen spring-knob (1-2 turns counter-clockwise)
- pull back on knob to retract pin from tube hole, and raise/lower kip bar to desired location
- release knob, assuring that the pin goes into the appropriate tube hole
- tighten knob (turning clockwise) until knob is fully seated against the tube, holding it securely

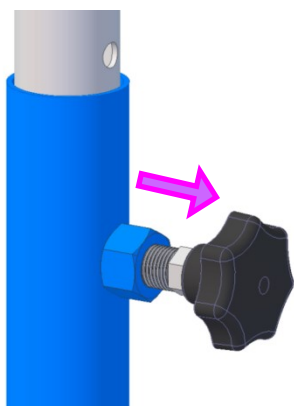

Example – detent-pin is protruding



Example – detent-pin is retracted



NOTE: Tumbl Trak equipment is not recommended for the use in **Parkour/Free Running** related activities.

General Guidelines
(125 lb. limit)



Tumbl Trak
Train Smart

Accessories for the Jr. Bar Pro

The following accessories can be purchased from Tumbl Trak's website at www.tumbltrak.com or by calling 1-800-331-4362.



Cast Trainer

- Use to create a mini set of uneven bars or use in a team program for casting, pirouetting and much more
- Easily attaches to the Jr. Bar Pro



Bar Pad

- Developed for the smaller athlete
- Easily attaches to bar with Velcro
- Measures 9.5" wide and 1.5" in diameter



4'x6'x6" Mat

- Provides softer base for skills
- May be used for tumbling skills when not in use with the Jr. Bar Pro
- Folds in 1/2 and has handles for ease of transport
- Non-skid material on the bottom prevents sliding



Air Barrel and Cradle

- This is a great station to use with your Jr. Bar Pro
- Put the Air Barrel behind the bar and do drills for Kips and straight arm bouncy butt drills
- Let your imagination go and you will discover so much more



For questions or problems, please call Tumbl Trak at
(800) 331-4362